

DeLaval International AB

DeLaval cubicle divider

Model CC1800 and CC1800XL

DLG Test Report 5821

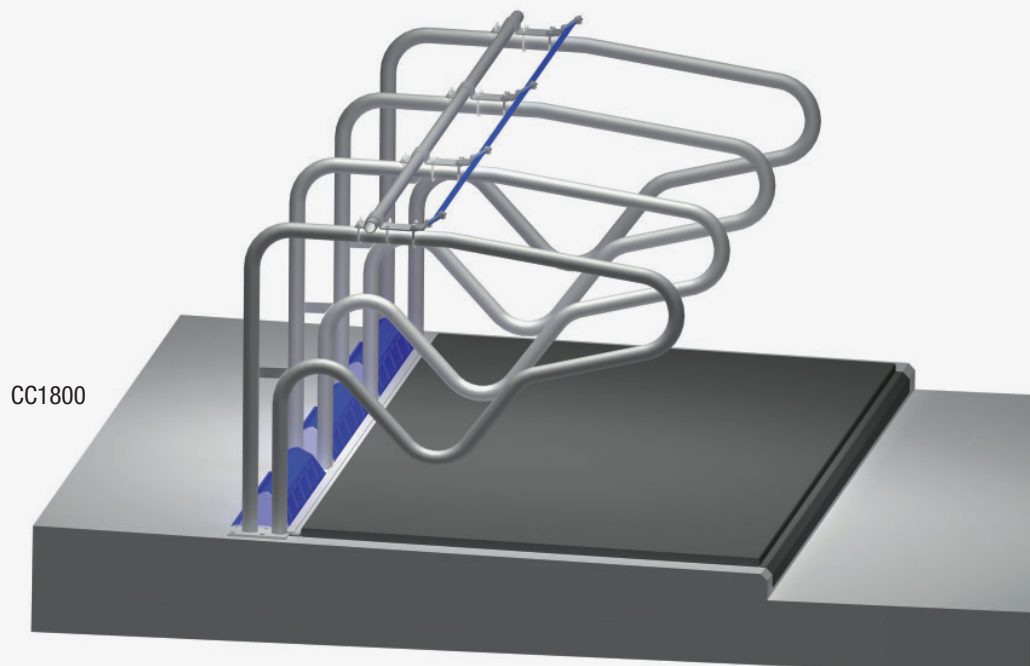

Registering company

DeLaval International AB
Box 39

SE-14721 Tumba/Schweden

Telephone: 0049 40 3033443-15

Telefax: 0049 40 3033443-49

e-mail: Lukas.Wolbeek@delaval.com

web: www.delaval.com

Short description

- Self-supporting cubicle divider for installation on an assembly foot.
- Model CC1800:
without head pipe, with neck pipe and neck belt (height: 124 cm).
- Model CC1800XL:
without head pipe, with neck pipe and neck belt (height: 130 cm).

(Specifications see page 2.)

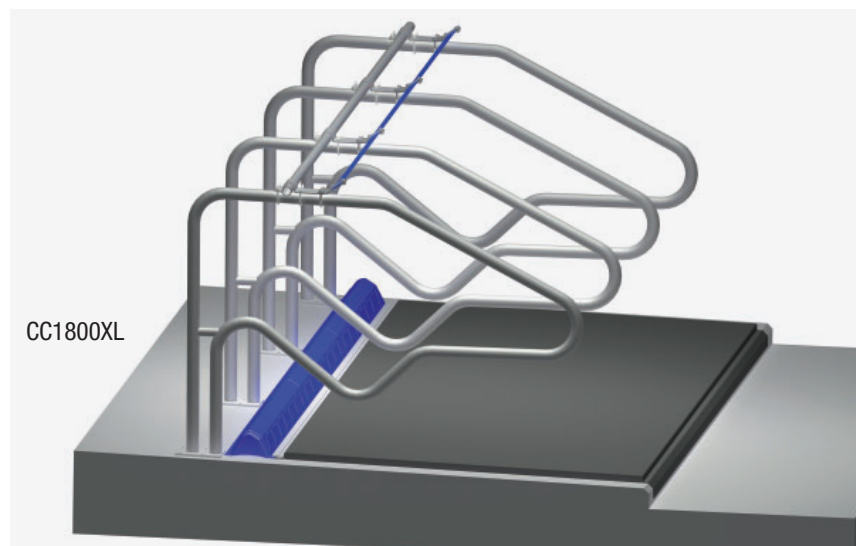

German Agricultural Society
DLG Test Centre
Technology and Farm Inputs

Evaluation – summary

Tested feature	Test result	Evaluation
Suitability		
for the partitioning of cubicle divider as high or low boxes for cows and cattle of different races		
Technical criteria		
Installation		
	The installation plan is clear and understandable	+
	Installation by the owner is possible	+
Durability		
	Very good during the test period	++
	Traces of wear in the neck belt of CC1800XL	○
Warranty		
Warranty period one year		
Animal-related criteria		
Behaviour		
Motions of the animals during	lying down: not influenced (CC1800)	++
	getting up: influenced (CC1800)	○
	lying: slightly influenced (CC1800)	+
	standing: influenced (CC1800)	○
	lying down: not influenced (CC1800XL)	++
	getting up: slightly influenced (CC1800XL)	+
	lying: slightly influenced (CC1800XL)	+
	standing: slightly influenced (CC1800XL)	+
Injuries		
	have not been observed so far	+
Cleaning		
	of the resting boxes and the animals: good	+

Evaluation range: ++ / + / ○ / - / -- (○ = standard)

Description and specifications (measured values)

Pipe and galvanization qualities

(information provided by the manufacturer)

All metal parts including the bolts are galvanized according to ISO 1461 1999.

Installation

according to the instructions of the manufacturer

Warranty period

one year

Main dimensions and weight

CC1800

Length, partition bar	1680 mm
Height, partition bar	1240 mm
Pipe diameter (2")	60 mm
Wall thickness	2,9 mm
Weight	17,7 kg

CC1800:XL

Length, partition bar	1930 mm
Height, partition bar	1310 mm
Pipe diameter (2")	60 mm
Wall thickness	3,6 mm
Weight	38 kg

I. SUITABILITY

The DeLaval cubicle divider model CC1800 is suitable for the partitioning of resting areas for cattle and dairy cows up to a live weight of 600 kg.

The DeLaval cubicle divider model CC1800XL is also suitable for the partitioning of resting areas for dairy cows having a live weight of more than 600 kg.

II. TECHNICAL CRITERIA

Installation

The installation of the cubicle divider requires craft skills. With the aid of the installation plan, this work can be carried out by the owner. Two persons are needed for installation. The installation plan is clear and understandable.

Durability

During the one-year test period, durability was very good. No obvious damage or corrosion was found. In model CC1800XL, the neck belt showed slight traces of wear.

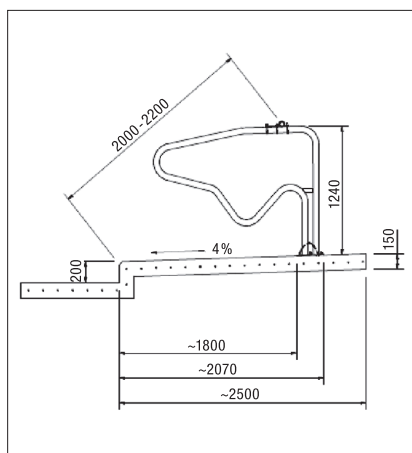

Figure 3:
System drawing DeLaval cubicle divider CC1800

III. ANIMAL-RELATED CRITERIA

Behaviour of the animals

The behaviour and the motions of the animals were documented by means of direct and video observation. The motions of the animals are influenced by the cubicle dividers.

Model CC1800

The swinging motion of the head during lying down is not influenced. Getting up is influenced by the neck pipe height of 1.24 m. The design of the partition only slightly influences proper lying. The position of the neck pipe influences standing in the resting box.

Model CC1800XL:

The swinging motion of the head during lying down is not influenced. Getting up is slightly influenced by the neck pipe height of 1.30 m.

The design of the partition only slightly influences proper lying.

The position of the neck pipe and the neck belt slightly influences standing in the resting box.

Evaluation range: not influenced: ++ /
slightly influenced: + / influenced: o /
impaired: - / significantly impaired: --

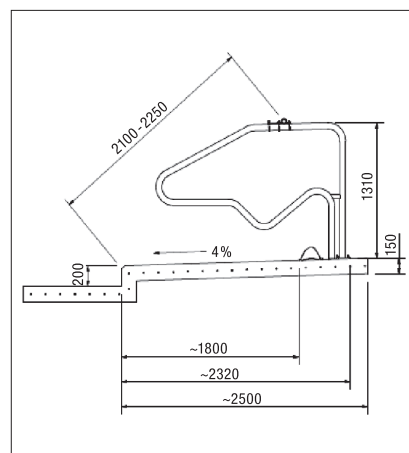

Figure 4:
System drawing DeLaval cubicle divider CC1800XL

Injuries

During the practical test period, which has lasted 12 months so far, injuries caused by the cubicle dividers or wedging-in of animals have not been observed.

Cleaning

Keeping the resting boxes clean is well achieved after assembly according to the installation guidelines and if the permitted box width is observed, taking animal size into consideration. In order to keep the resting boxes clean, regular checks and box care (daily) are recommended.

IV. SURVEY RESULT

A survey carried out on 10 farms which have used a total of 291 cubicle dividers for up to 2 years largely confirms the test results. 90% of the farmers installed the partitions themselves, and all of them stated that installation was easy.

On 70% of the farms, the resting boxes are well accepted, and 90% of the farms confirm that the animals were largely able to move freely.

90% of those surveyed were satisfied with the cubicle divider, and 80% gave it a good or very good overall evaluation. If necessary, 80% would install the cubicle divider again.

The DLG SignumTest is based on practical tests and behavioural observations with the cubicle dividers installed on the test farm. During the evaluations, the effects of the cubicle divider on cleanliness and freedom of motion as well as the behaviour and the health of the animals were assessed. In addition, the durability of the housing system was evaluated.

Realization of the test

DLG Test Centre
Technology and Farm Inputs,
Max-Eyth-Weg 1,
D-64823 Groß-Umstadt

Landwirtschaftszentrum
Haus Düsse,
D-59505 Bad Sassendorf

Practical tests

Landwirtschaftszentrum
Haus Düsse,
D-59505 Bad Sassendorf

Reporting engineer

Dr. H. Reubold,
Groß-Umstadt

DLG Committee for Animal Welfare

Ms. Dr. sc. agr. C. Müller,
Trenthorst

Published

with the support of the Federal
Ministry of Food, Agriculture, and
Consumer Protection.

DLG test panel

Dr. agr. S. Pache,
Köllitsch

Dipl.-Ing. A. Pelzer,
Bad Sassendorf

R. Schmidt, Ronneburg

Dipl.-Ing. agr. K.W. Wolf,
Höchst

Dr. med. vet./Dipl.-Ing. agr.
W. Wolter,
Giessen



ENTAM – European Network for Testing of Agricultural Machines, is the association of European test centres. It is the goal of ENTAM to spread test results Europe-wide to farmers, agricultural machinery dealers and manufacturers.

You will find more information about the network under www.entam.com or under the e-mail address: info@entam.com

9/2008
© DLG



German Agricultural Society
DLG Test Centre Technology and Farm Inputs

Max-Eyth-Weg 1, D-64823 Groß-Umstadt, Telephone: 069 24788-600, Fax: 069 24788-690
e-mail: Tech@DLG-Frankfurt.de, web: www.dlg-test.de

Downloading of all DLG-test reports from: www.dlg-test.com!